



GMV-01 MINI VACUUM TESTER



Product parameters

Effect

Lux: 17L/min

Positive pressure : 60kPa

Negative pressure : -60kPa

Protection rating

IP20

Display

LCD display

Software



Firmware upgrade: upgrade via USB link

Electric parameter

AC100-240V,50/60Hz

Working power : 50W

Standby power : 3W

Dimensions and weight

Product dimensions : 415x336x175mm

Packing dimensions (carton) : 500x415x285mm

Net weight : 6kg

Gross weight (carton) : 7.5kg

Colours/ Gobos

:

:

:

Dimensions

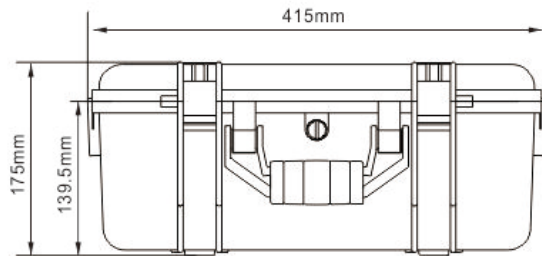
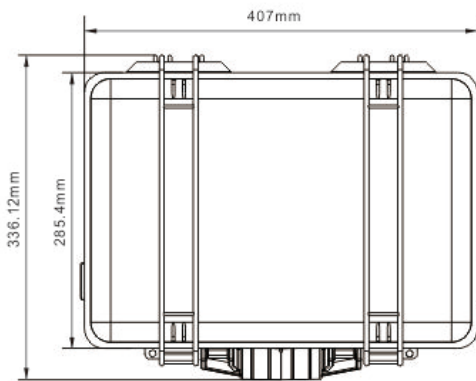

Errors and omissions are possible. All specifications are subject for change without prior notice.